



FEATURES

- Carbon resistive element.
- High mechanical endurance.
- Upon request:
 - Detents
 - Stereo matching
 - Switch
 - Nut & washer

MECHANICAL SPECIFICATIONS

- Mechanical rotation angle: $300^\circ \pm 5^\circ$
- Electrical rotation angle: $280^\circ \pm 20^\circ$
- Torque: 0.5 to 1.5 Ncm.
(0.7 to 2.1 in-oz)
- Stop torque: > 40 Ncm. (> 56 in-oz)

ELECTRICAL SPECIFICATIONS

- Range of values (*)
 $100\Omega \leq R_n \leq 5\text{ M}$ (Decad. 1.0 - 2.0 - 2.2 - 2.5 - 4.7 - 5.0)
- Tolerance (*): $100\Omega \leq R_n \leq 1\text{M}\Omega$ $\pm 20\%$
 $1\text{M}\Omega < R_n \leq 5\text{M}\Omega$ $\pm 30\%$
- Max. Voltage: 250 VDC (lin) 125 VDC (no lin)
- Nominal Power 50°C (122°F) (see power rating curve)
0.2 W (lin) 0.1 W (no lin)
- Taper (*) (Log. & Alog. only $R_n > 1\text{K}$) Lin ; Log; Alog.
- Residual resistance(*): $\leq 0.5\% R_n$ (5 Ω min.)
- Equivalent Noise Resistance: $\leq 3\% R_n$ (3 Ω min.)
- Operating temperature**: $-25^\circ\text{C} + 70^\circ\text{C}$ ($-13^\circ\text{F} + 158^\circ\text{F}$)

* Others upon request

** Up to 85°C depending on application

HOW TO ORDER

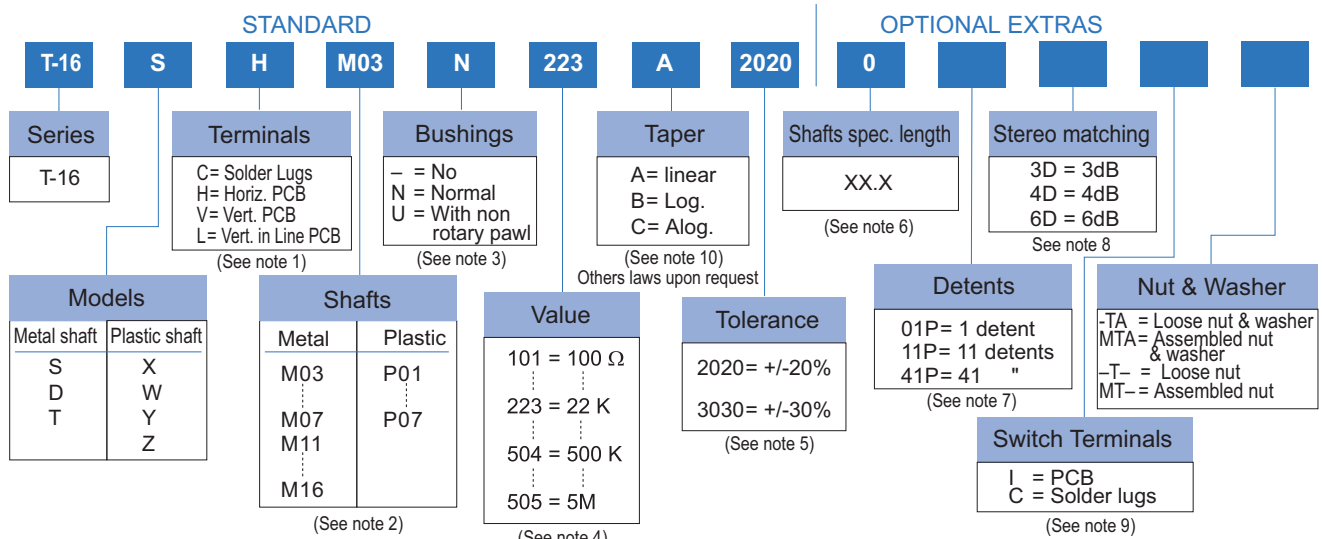

NOTES:

- Terminals: Models D y T are not available with terminals "V" or "L".
- Shafts: The codes indicate diameter and length. Shaft M05 only for double potentiometer.
- Bushings: - = Only for potentiometer model X, W.
U = Standard antirotation lugs (at 90° CW).
- Value:
 - Code: $\frac{10}{1} \frac{100}{\Omega}$ → Number of zeros / 2 first digits of the value.
 - In models "D" and "T" with different values, ask by drawing.
- Tolerance (non standard), upon request. Example code: $\frac{15}{-20}$ → negative tolerance / positive tolerance
- Shafts length:
 - Only for special length and plain shafts (not knurled). Example: Shaft $\varnothing 6,25$ L= 24.5 M07 24.5 → Shafts length / shafts
 - Flatted and slotted shafts, etc. will need drawings.
 - Shaft M05 (T-16D) with other lengths, ask by drawing. NOTE: Max. length 40 mm. (shafts 4, 6, 6.25)
- Detents: - Not available for models with plastic shaft X, W, Y, Z.
- Detents and switch are not compatible.
- Stereo matching: Only available in tandem models and upon request.
- Switch: Not available for models X, W, Y, Z, T, D.
- Switch option not available with antilog taper.

NOTE: The information contained here should be used for reference purposes only.

T-16 SH + DRAWING NUMBER (Max. 16 digits)

This way of ordering should be used for options which are not included in the "How to order" standard and optional extras.

Shaft length 0 standard length
 Detents Not included
 Stereo matching Only for model "T" and upon request
 Switch No switch
 Nut & washer Without nut and washer

MODELS WITH METALIC SHAFTS

T-16 S ...

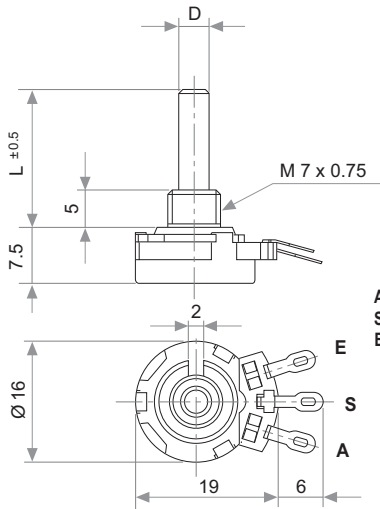

T-16 T ...

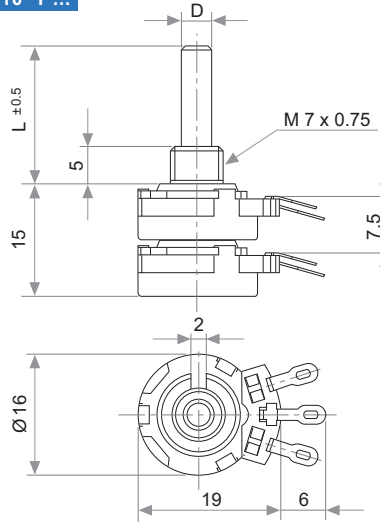

T-16 D ...

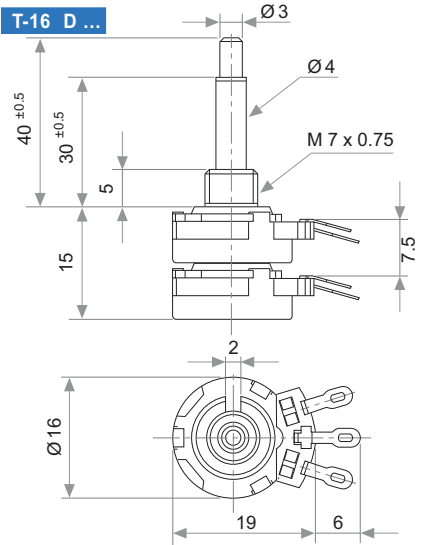

A = Initial
 S = Wiper
 E = Final

MODELS WITH PLASTIC SHAFTS

T-16 X ...

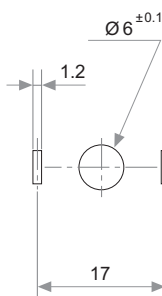
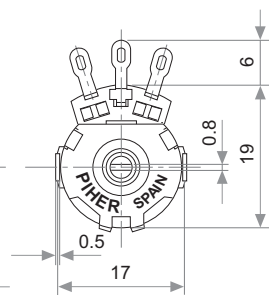
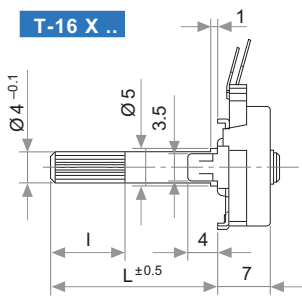

T-16 W ...

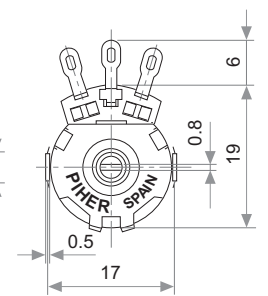
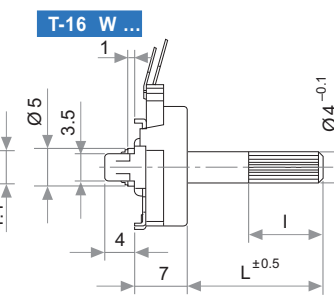

T-16 Y ...

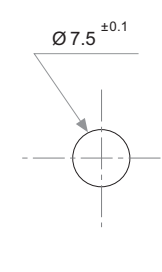
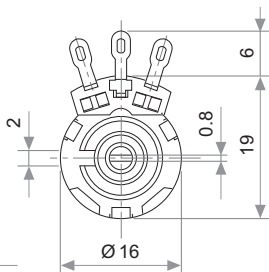
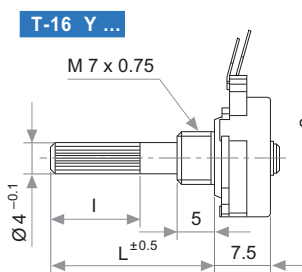

T-16 Z ...

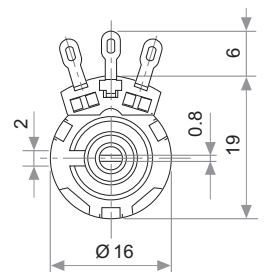
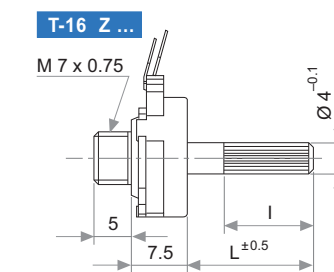

TERMINALS

T-16 .. C ...

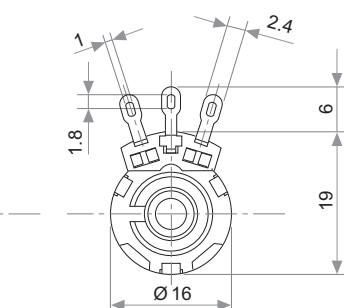
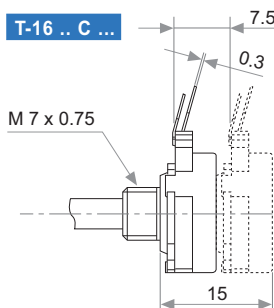

T-16..H..

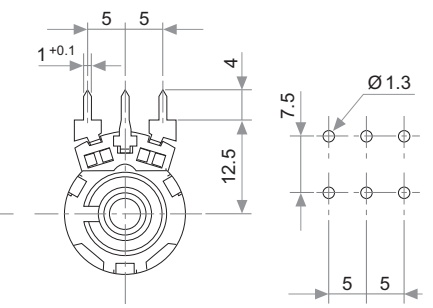
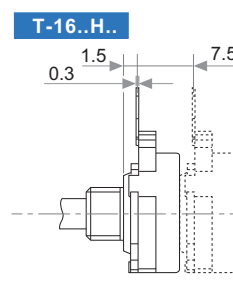

T-16 .. V ...

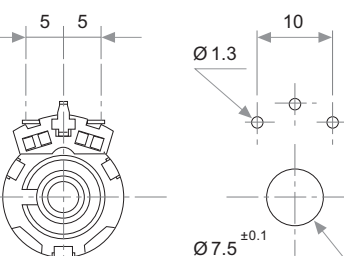
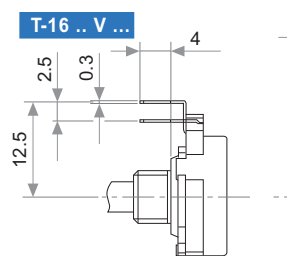

T-16..L..

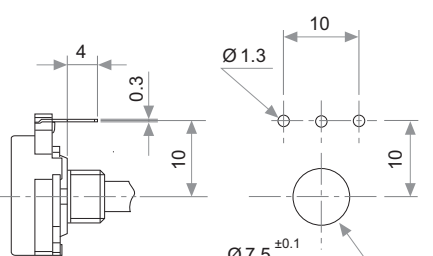
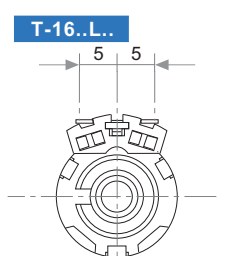

PLASTIC SHAFTS

T-16 X / Y		Without Switch		CODE
T-16 X		T-16 Y		
L	I	L	I	
2	—	—	—	P01
21	12	20.5	12	P02
24.5	15	24	15	P03
40	31	39.5	31	P04

T-16 W / Z		Without Switch	CODE
T-16 W	& T-16 Z		
L	I		
9.5	5		P05
23.5	19		P06
40	35		P07

METALIC SHAFTS

PLAIN SHAFT

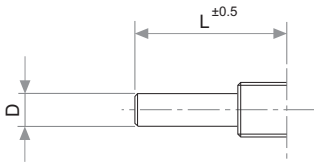

D	L	CODE
3	30	M03
4	40	M04
6	40	M06
6.25	40	M07
3/4	40/30	M05

KNURLED SHAFT

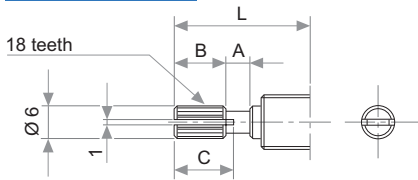

L	A	B	C	CODE
15	2	6	7	M11
20	2	10	11	M12
25	4	12	14	M13
30	4	12	14	M14
35	4	12	14	M15
40	4	12	14	M16

UNDER DRAWING

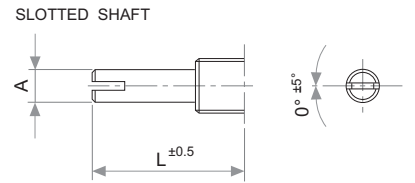
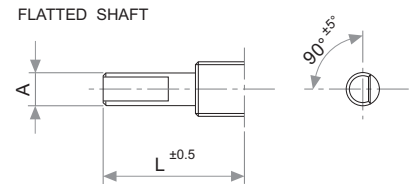

BUSHINGS

T-16 .. N ...

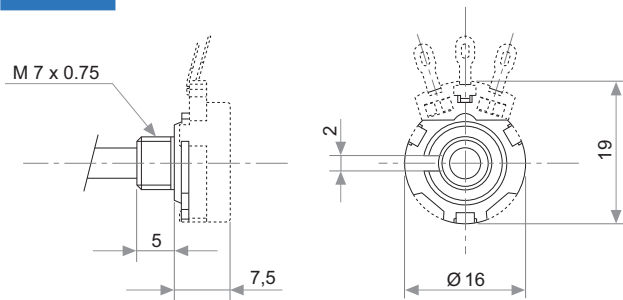

T-16 .. U ...

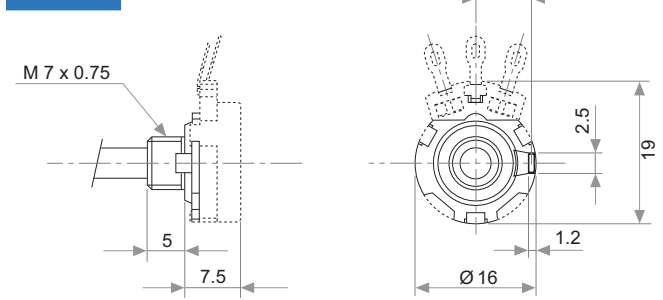

DETENTS

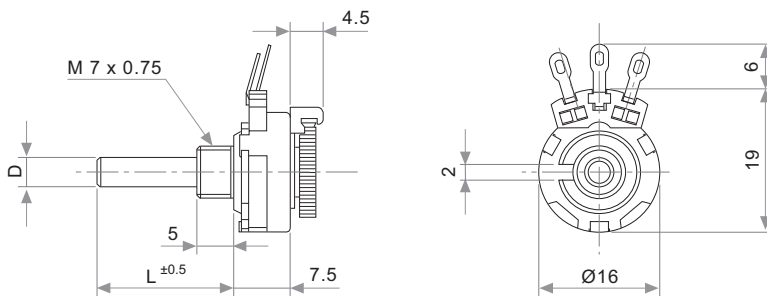

CODE	DETENTS
01 P.	1 detent (at 50%)
11 P.	11 detents
41 P.	41 detents

Only models with metallic shaft.

TAPERS

Standard

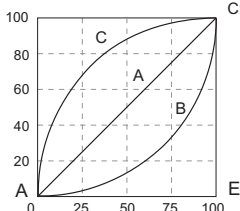

A: Lin.
B: Log.
C: Alog.

POWER RATING CURVE

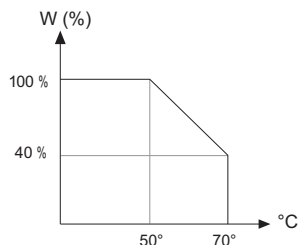

NUT & WASHER

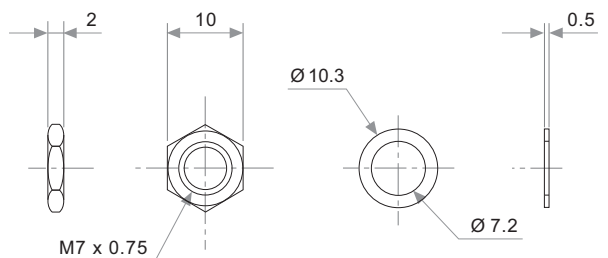

TESTS		TYPICAL VARIATIONS
ELECTRICAL LIFE	1.000 h.@ 50°C; 0.20 W	± 5 %
MECHANICAL LIFE : POT. SWITCH	25.000 (10–15 CPM) 10.000 (1A, 50 VAC)	± 3 % (Rn < 1 MΩ)
TEMPERATURE COEFFICIENT	-25°C; +70°C	± 300 ppm (Rn < 100 K)
THERMAL CYCLING	16 h. @ 85°C; 2h. @ -25°C	± 2.5 %
DAMP HEAT	500 h. @ 40°C @ 95% HR	± 5 %
VIBRATION (each plane X,Y,Z)	2 h. @ 20 g. 10 Hz ... 55 Hz.	± 2 %

NOTE: Out of range values may not comply these results.

SWITCH

T-16..C..C

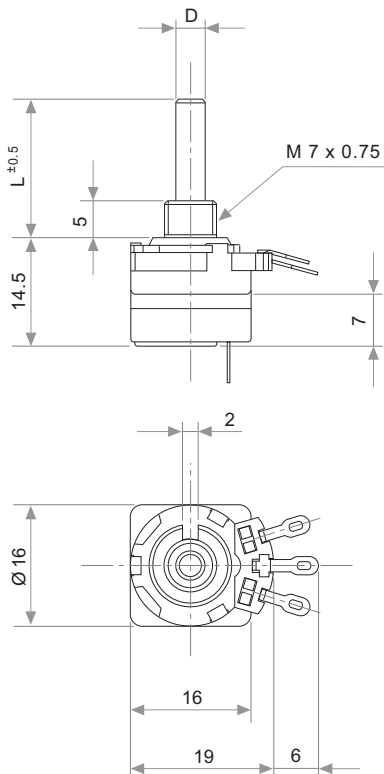

T-16..H..I

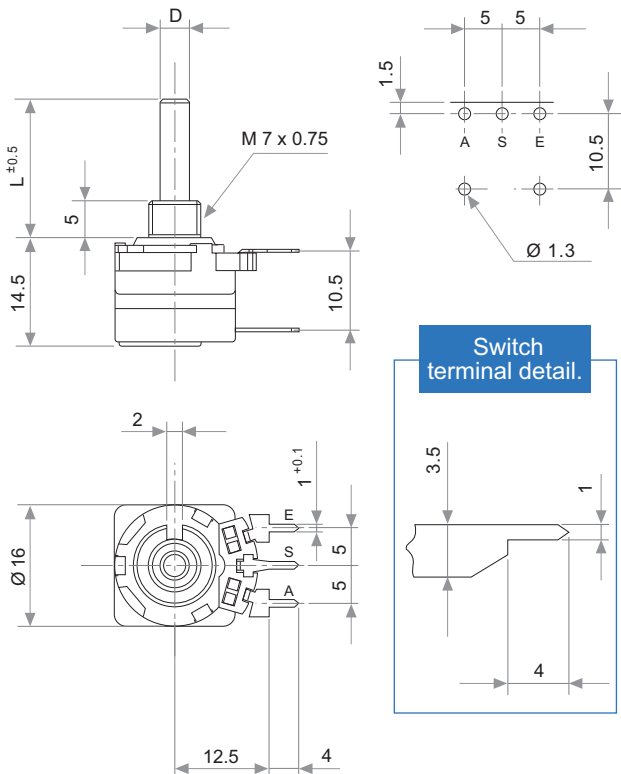

SWITCH SPECIFICATIONS

NOMINAL CURRENT	1A, 250 VAC
CONTACT RESISTANCE (Initial)	10mΩ
OPERATING TORQUE	1 to 3 Ncm (1.4 to 4.2 in-oz)
OPERATING ANGLE	30° ± 5°
TEST VOLTAGE	500 V

PACKAGING

MODEL	PACKAGING
T 16 – L = 40 mm.	400 UNITS IN BOX
T 16 – L = 20 mm.	600 UNITS IN BOX
T 16 – c/i – Tandem	200 UNITS IN BOX