

FEATURES

- Carbon resistive element.
- Dust proof enclosure.
- With or without actuating knob
- Optional SPST switch

MECHANICAL SPECIFICATIONS

- Mechanical rotation angle: $255^\circ \pm 5^\circ$
- Electrical rotation angle: $220^\circ \pm 20^\circ$
- Torque: 0.5 to 1.5 Ncm.
(0.7 to 2.1 in-oz)
- Stop torque: > 40 Ncm. (> 56 in-oz)

ELECTRICAL SPECIFICATIONS

- Range of values (*)
 $100\Omega \leq R_n \leq 5\text{ M}$ (Decad. 1.0 - 2.0 - 2.2 - 2.5 - 4.7 - 5.0)
- Tolerance (*): $100\Omega \leq R_n \leq 1\text{M}\Omega$ $\pm 20\%$
 $1\text{M}\Omega < R_n \leq 5\text{M}\Omega$ $\pm 30\%$
- Max. Voltage: 200 VDC (lin) 100 VDC (no lin)
- Nominal Power 50°C (122°F) (see power rating curve)
0.25 W (lin) 0.12 W (no lin)
- Taper (*) (Log. & Alog. only $R_n > 1\text{K}$) Lin ; Log; Alog.
- Residual resistance(*): $\leq 0.5\% R_n$ (5Ω min.)
- Equivalent Noise Resistance: $\leq 3\% R_n$ (3Ω min.)
- Operating temperature**: $-25^\circ\text{C} + 70^\circ\text{C}$ ($-13^\circ\text{F} + 158^\circ\text{F}$)

* Others upon request

** Up to 85°C depending on application

HOW TO ORDER

STANDARD

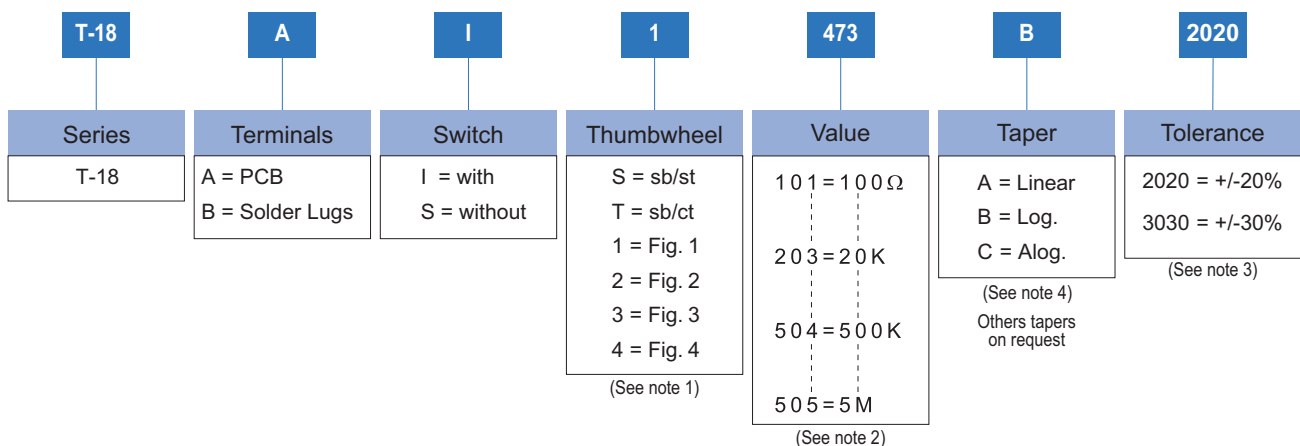

NOTES:

- (1) Thumbwheel: S = without knob, without screw
T = without knob, with screw
Fig. 1, 2 y 3: countersunk knob
Fig. 4: knob with screw
knob colour: Black

- (2) Value: • Code: $\begin{matrix} 10 & 1 & 100\Omega \\ \downarrow & \downarrow & \downarrow \\ \text{Number of zeros} & & \text{2 first digits of the value.} \end{matrix}$
Others values upon request.

- (3) Tolerance (non standard), upon request.
Rotary switch with Alog. curve is not available.
- (4) Switch option not available with antilog taper.

Example code: $+7 = \begin{matrix} 07 & 05 \\ \downarrow & \downarrow \\ \text{negative tolerance} & \text{positive tolerance} \end{matrix}$

NOTE: The information contained here should be used for reference purposes only.

HOW TO ORDER CUSTOM DRAWING

T-18 A I + DRAWING NUMBER (Max. 16 digits)

This way of ordering should be used for options which are not included in the "How to order" standard and optional extras.

TERMINALS

T-18 A

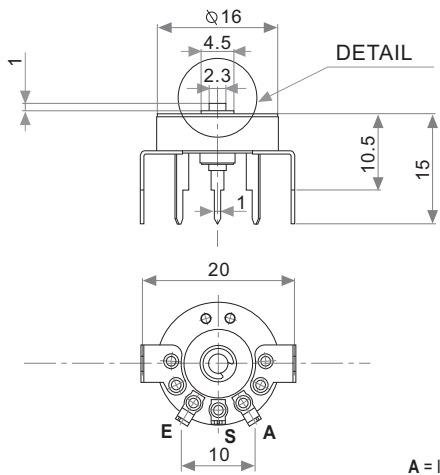

DETAIL

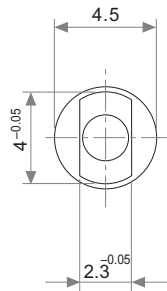

T-18 B

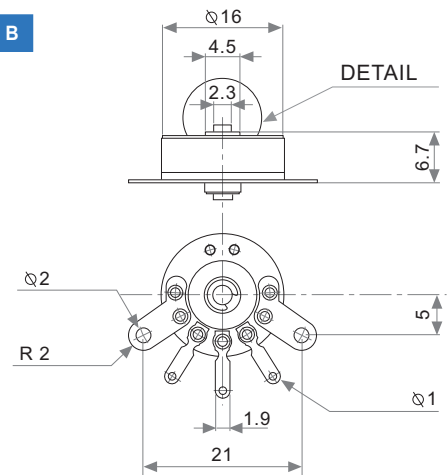

A = Initial S = Wiper E = Final

SWITCH

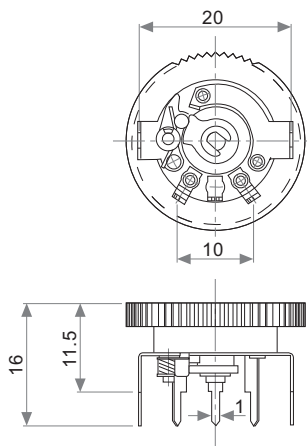

ELECTRICAL AND MECHANICAL	
SWITCH RATING	0.5 A; 12V DC
SWITCH OPERATING ANGLE	25°±10°
MECHANICAL LIFE (CYCLES)	10.000

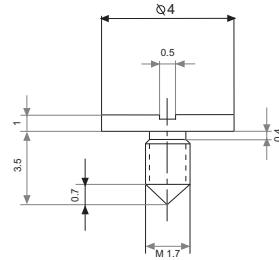

SCREW

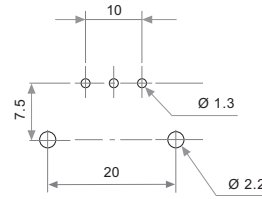

FOOTPRINT

POWER RATING CURVE

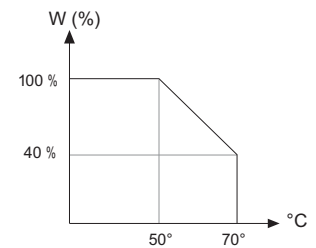

THUMBWHEEL

Fig. 1 / Ref. 5950

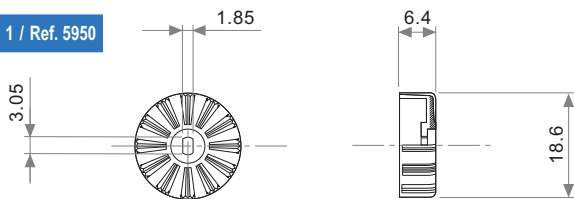

Fig. 2 / REF. 5951

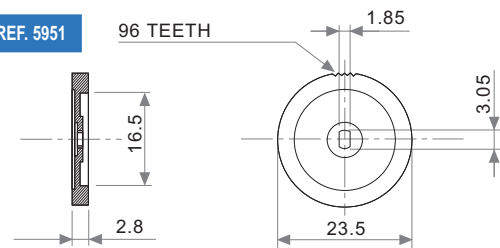

Fig. 3 / Ref. 5952

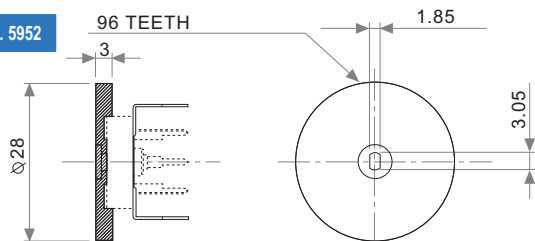
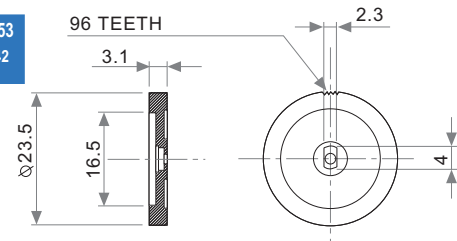

Fig. 4 / Ref. 5953
(Screw Ref. 5342 is required)



TESTS

TYPICAL VARIATIONS

ELECTRICAL LIFE	1.000 h. @ 50°C; 0.25 W	±5 %
MECHANICAL LIFE : POT.	25.000 (10-15 CPM)	±3 % (Rn < 1 M)
TEMPERATURE COEFFICIENT	-25 °C; +70 °C	±300 ppm (Rn < 100 K)
THERMAL CYCLING	16 h. @ 85 °C; 2h @ -25 °C	±2.5 %
DAMP HEAT	500 h. @ 40 °C @ 95% HR	±5 %
VIBRATION (for each plane X,Y,Z)	2 h. @ 10 Hz - 55 Hz.	±2 %

NOTE: Out of range values may not comply these results.